

ZIPTRAK® BLIND ASSEMBLY (EXPLODED VIEW)

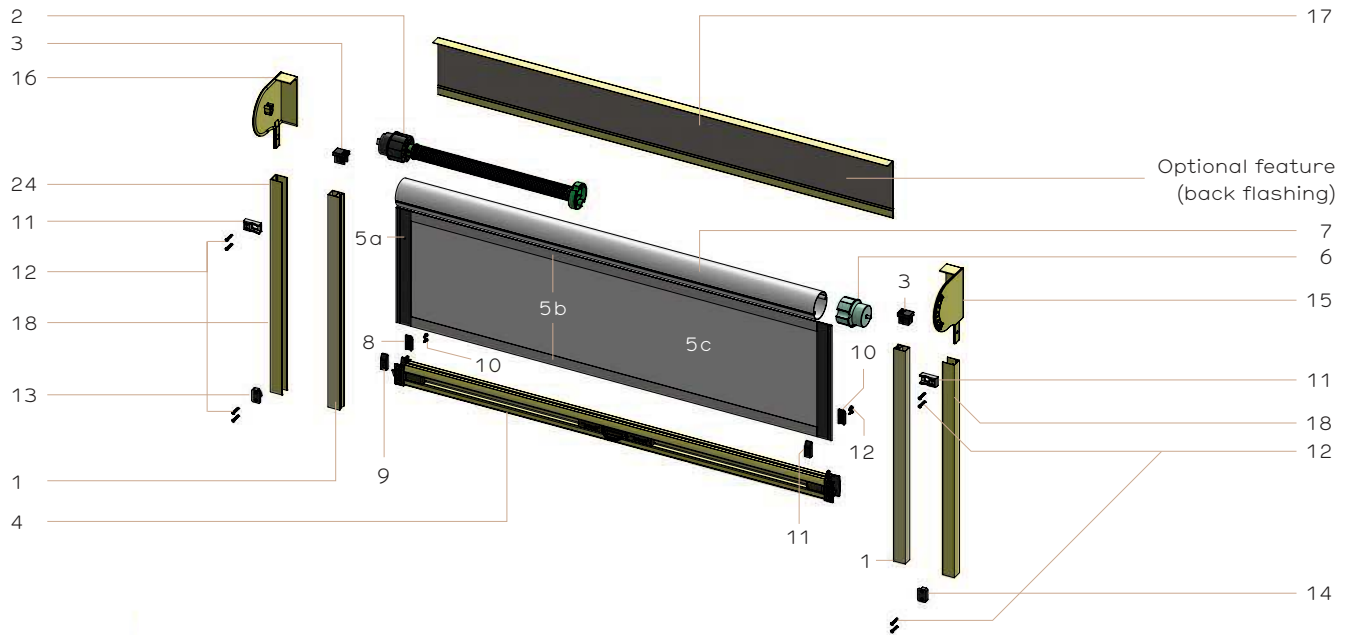

- 1 Ziptrak® track 2 Short spring assembly 3 Guide funnel 4 Aluminum bottom rail, center-lock-release & accessories
- 5a Spline tape 5b Top & bottom PVC spline 5c Fabric 6 Idler assembly 7 63mm Keyway tube
- 8 Fabric clamp (holes part) 9 Fabric clamp (no holes part) 10 Pan head tapping screw 11 Top stop
- 12 Flat countersunk head tapping screw 13 Left hand lock catch 14 Right hand lock catch 15 Right hand cast end bracket
- 16 Left hand cast end bracket 17 Back flashing (optional) 18 30-25mm Bracket channel

NOTE: Item No.2 - Spring sizes will vary depending on the length of the blind. See Fabrication Manual for appropriate spring selection.

ZIPTRAK® BLIND ASSEMBLY

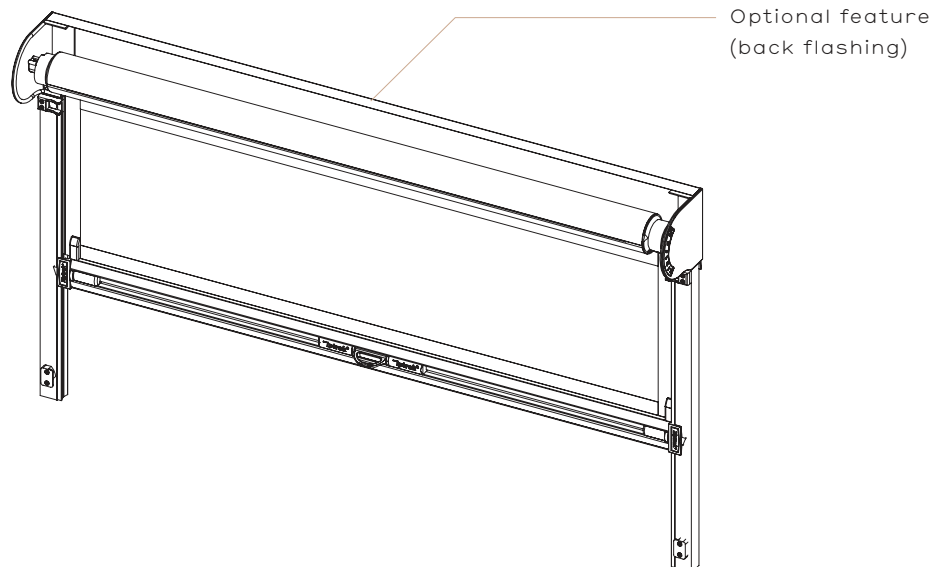

PELMET / FRONT VIEW (mm)

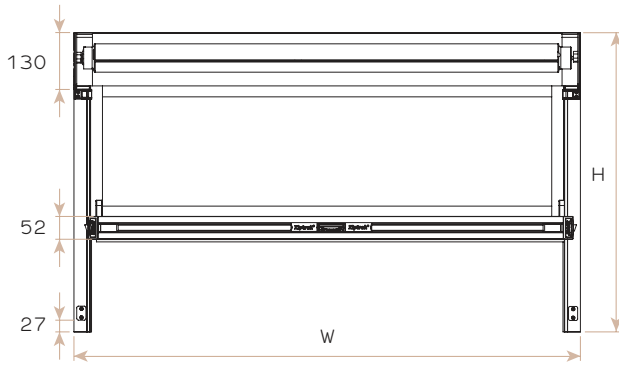

PELMET / SIDE VIEW (mm)

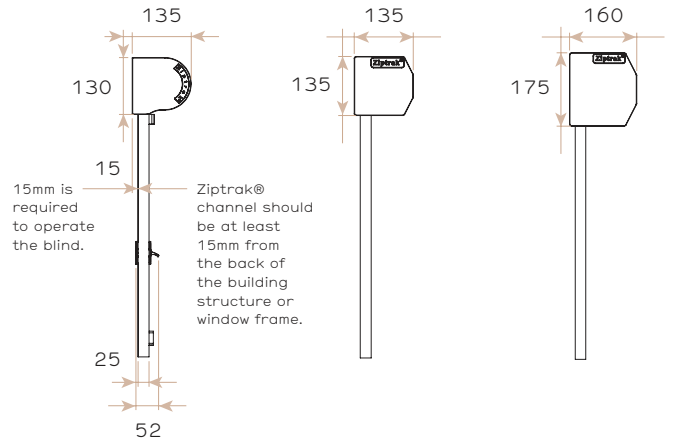

OPTION 1
Cast bracket.

OPTION 2
135mm End plate
(comes with a fully enclosed pelmet).

OPTION 3
175mm End plate
(comes with a fully enclosed pelmet).

PELMET / TOP VIEWS (mm)

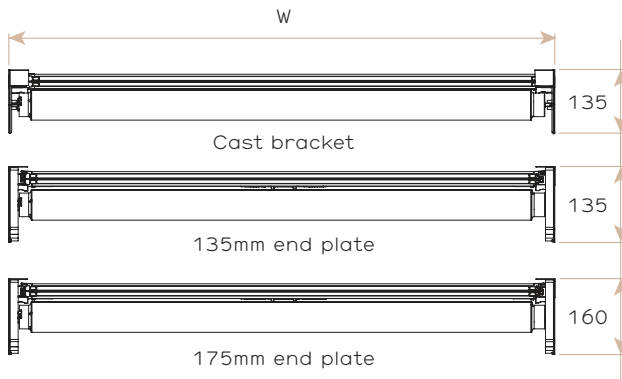

PELMET / SIZES

To fully enclose the Ziptrak® blind, two sizes of pelmet are offered:

- 1 Ziptrak® 135mm aluminium pelmet.
- 2 Ziptrak® 155mm aluminium pelmet.

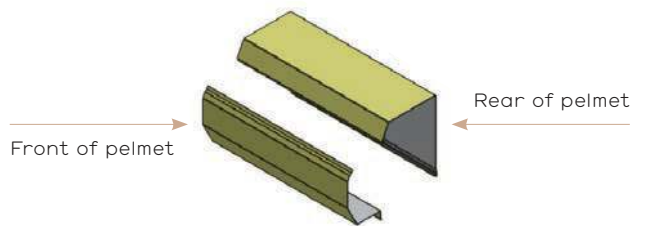

Pelmet end plates to be used with the pelmets.

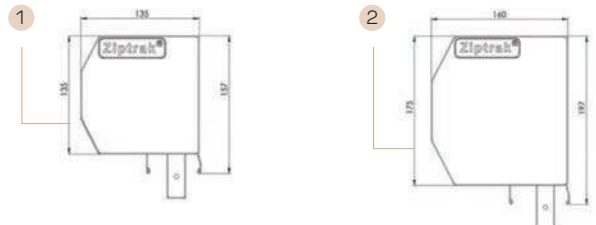

FRONT VIEW / FULLY CLOSED BLIND

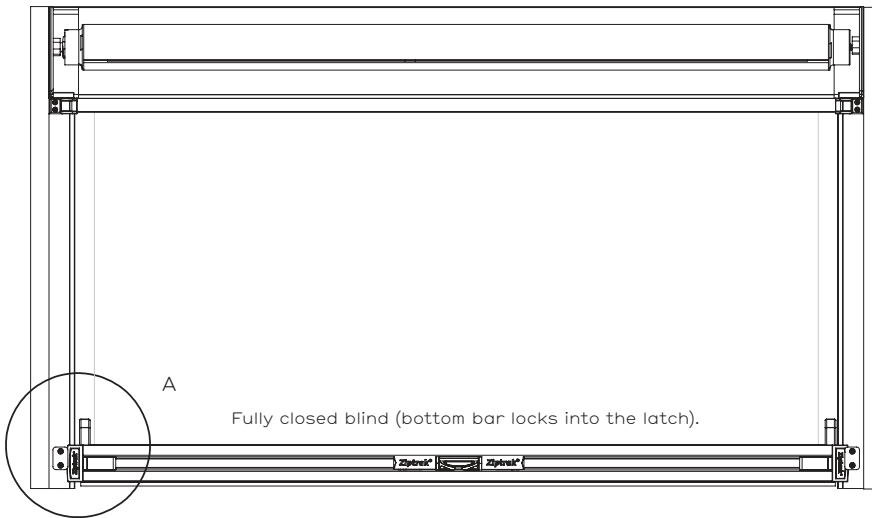

DETAIL A

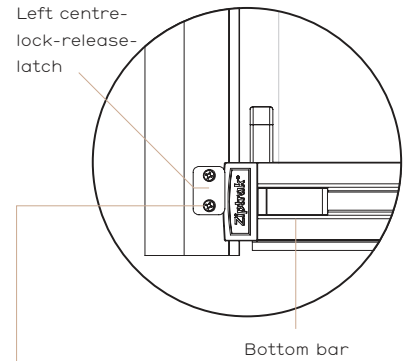

The placement of the latch is done by an experienced installer and its exact location will depend on the leveling of the blind. Allow enough space for the bottom bar to clear the latch when being pulled down.

FRONT VIEW / FULLY OPEN BLIND

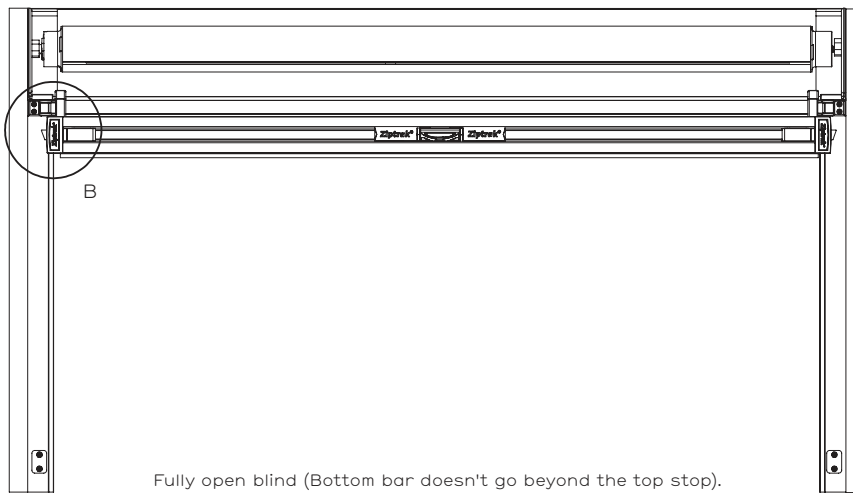

DETAIL B

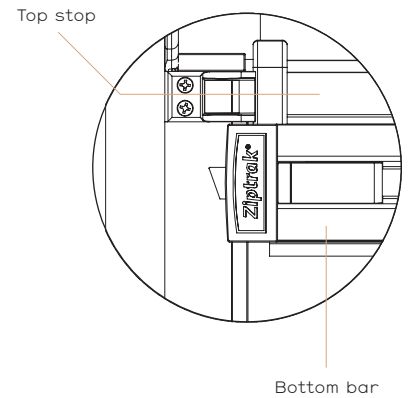

REVEAL — CAST BRACKET

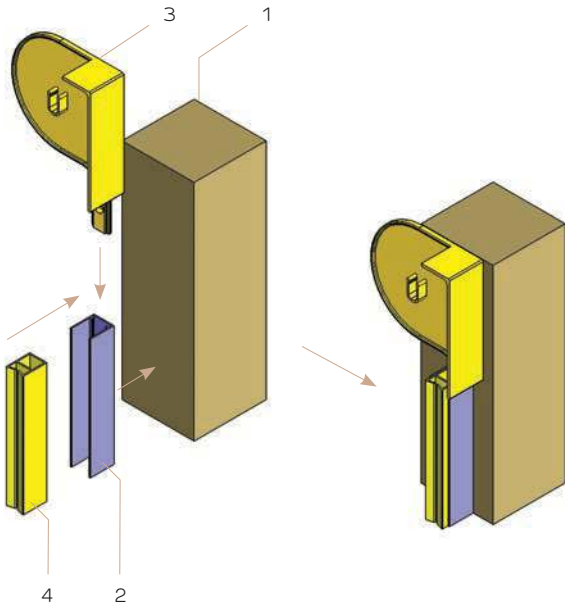

INNER SIDE (mm)

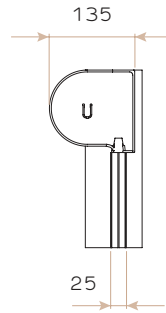

OUTER SIDE (mm)

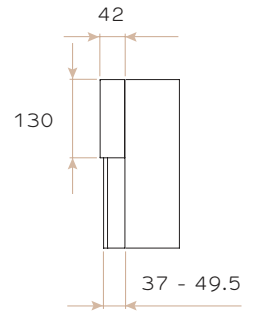

TOP (mm)

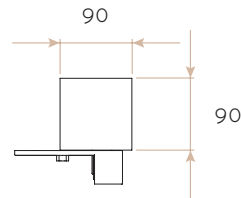

- 1 90 × 90mm Veranda Post
- 2 30 × 25mm Bracket channel
- 3 Ziptrak® cast end bracket L/H
- 4 Ziptrak® track 30 × 21.4mm

FACE FIX INSTALLATION REVEAL — CAST BRACKET

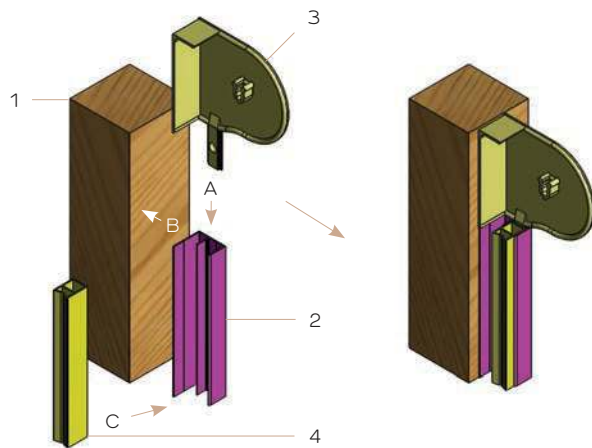

INNER SIDE (mm)

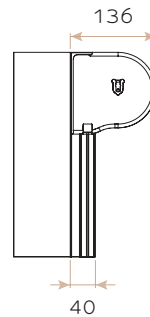

OUTER SIDE (mm)

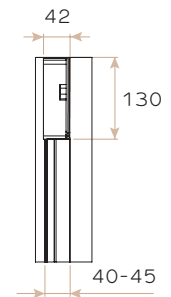

TOP (mm)

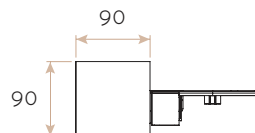

- 1 90 × 90mm Veranda post
- 2 Exterior face fix channel
- 3 Ziptrak® cast end brackets R/H
- 4 Ziptrak® track

A — Insert the 'leg' of the cast end bracket, or pelmet end plate into the face fix channel.
 B — Fix the face fix channel and cast end bracket, or pelmet end plate to the post using fasteners to suit the

post material. The fasteners should not be more than 500mm apart.
 C — Insert the track into the face fix channel and fasten using 4mm aluminium, or stainless steel rivets. The first rivet should be 200mm under

the guide funnel at the top of the track, the rest of the rivets should not be more than 500mm apart.

50 X 50 X 1.6 ALUMINIUM REMOVABLE POST

